



Prestel IPC-4KJ2000-R2

Video over IP Controller V3



USER MANUAL

Thank you for purchasing this product

For optimum performance and safety, please read these instructions carefully before connecting, operating or adjusting this product. Please keep this manual for future reference.

Surge protection device recommended

This product contains sensitive electrical components that may be damaged by electrical spikes, surges, electric shock, lightning strikes, etc. Use of surge protection systems is highly recommended in order to protect and extend the life of your equipment.

Table of Contents

1. Introduction.....	1
2. Features.....	1
3. Package Contents.....	1
4. Specifications.....	2
5. Operation Controls and Functions.....	2
5.1 Front Panel.....	2
5.2 Rear Panel.....	3
5.3 IR Pin Definition.....	3
6. Rack Mounting Instruction.....	4
6.1 6U V2 Rack Mounting.....	4
6.2 1U V2 Rack Mounting.....	5
7. Web GUI Operation Guide.....	6
7.1 Preparation before Entering the System.....	6
7.2 Functions and Operation.....	14
7.2.1 Device.....	14
7.2.2 Matrix.....	24
7.2.3 Video Wall.....	26
7.2.4 Dante.....	29
7.2.5 User.....	34
7.2.6 Controller Settings.....	36
7.2.7 Firmware Update.....	37
7.2.8 Password	38
8. Application Example.....	39

1. Introduction

This Video over IP Controller is used to control and manage JPEG2000 IP products. It supports dual 1G network ports, which can realize dual-network isolation of Control network and Multicast video distribution network. The product supports Web GUI/TCP/RS-232/IR/GPIO controls and POE function. Since the demand of IP products is daily increased in the current market, the IP Controller will be widely applied in more and more different scenarios.

2. Features

- ☆ Easy to create project, control and manage the system
- ☆ Flexibly support Auto, DHCP and Manual three types of IP configurations
- ☆ HTTPS, SSH, SFTP security compatible
- ☆ Built-in Web GUI control interface, supporting Drag & Drop operations
- ☆ Support image preview
- ☆ Support video, audio, RS-232, IR, USB control and management of the distributed system
- ☆ Dual network ports (VIDEO LAN port supports POE function) to isolate Controls and Multicast networks.
- ☆ Support LAN/RS-232 port control and third-party central control
- ☆ Support IR signal receiving and loop output (3.5mm audio jack, 12V level)
- ☆ 4 channel GPIO control ports (5V/12V optional level)
- ☆ Multiple circuits protection, lightning protection and ESD design
- ☆ Reliable system design, ensuring 7*24 hours reliable and stable work

3. Package Contents

- ① 1x Video over IP Controller
- ② 1x 20kHz-60kHz 12V IR Receiver Cable (1.5 meters)
- ③ 1x IR Blaster Cable (1.5 meters)
- ④ 2x 3-pin 3.81mm Phoenix Connector (Male)
- ⑤ 1x 6-pin 3.81mm Phoenix Connector (Male)
- ⑥ 2x Mounting Ears
- ⑦ 4x Machine Screws (KM3*4)
- ⑧ 1x 12V/1A Locking Power Adaptor
- ⑨ 1x User Manual

4. Specifications

Technical	
Network Bandwidth	100M/1G
Transmission Distance	100m CAT 5E/6/6A/7
Control Ports	2x 1G LAN [RJ45 connector] [VIDEO LAN support POE] 1x IR IN [3.5mm audio jack, 12V level] 1x IR OUT [3.5mm audio jack] 1x DIGITAL I/O [6-pin 3.81mm phoenix connector] 2x RS-232 [3-pin 3.81mm phoenix connector] 1x UPDATE [Micro USB, 5-pin female]
ESD Protection	IEC 61000-4-2: ±8kV (Air-gap discharge) & ±4kV (Contact discharge)
Dimensions	204mm (W) × 98.5mm (D) × 21.5 mm (H)
Housing	Metal Enclosure
Color	Black
Weight	508g
Power Supply	12V/1A
Power Consumption	1.8W (Max.)
Operating Temperature	0°C ~ 40°C / 32°F ~ 104°F
Storage Temperature	-20°C ~ 60°C / -4°F ~ 140°F
Operating Humidity	20% ~ 80% RH (relative humidity, non-condensing)
Storage Humidity	10% ~ 90% RH (relative humidity, non-condensing)

5. Operation Controls and Functions

5.1 Front Panel

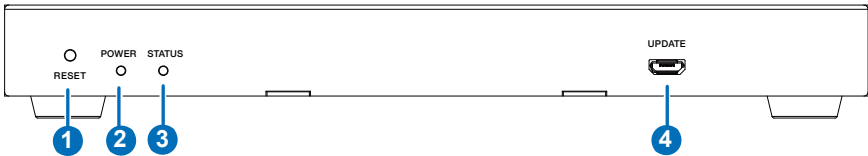

No.	Name	Function Description
1	RESET Button	Press and hold this button (about 10 seconds) until STATUS LED starts flashing, Controller will be reset automatically.
2	POWER LED	The red LED will light on when the Controller is powered on.
3	STATUS LED	The status LED will flash in yellowish-green every 1 second until Controller boots up completely and Control LAN is ready, then it becomes solid.
4	UPDATE	Firmware update port. <i>Note: Must keep no connection on this port when Controller works in normal mode.</i>

5.2 Rear Panel

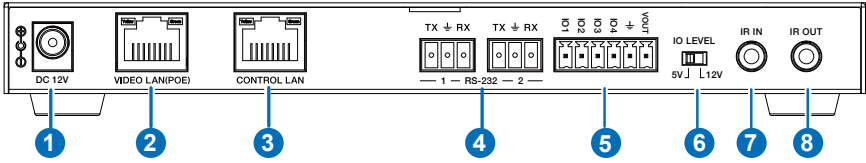

No.	Name	Function Description
1	DC 12V	DC 12V/1A power input port.
2	VIDEO LAN (POE)	1G Video LAN port, supporting POE function. <i>Note: When POE is enabled, DC 12V/1A power supply is not required.</i>
3	CONTROL LAN	The TCP/IP control network port.
4	3-pin Phoenix Connectors	Two identical RS-232 serial communication ports.
5	6-pin Phoenix Connector	4 channel I/O level outputs, 1 channel grounding, 1 channel power supply (supports up to 12V/0.5A) to the outside.
6	IO LEVEL DIP Switch	Used to control I/O level output and VOUT voltage. Switch to left: 5V I/O level output, VOUT is 5V. Switch to right: 12V I/O level output, VOUT is 12V.
7	IR IN	12V IR signal input port.
8	IR OUT	IR signal output port.

5.3 IR Pin Definition

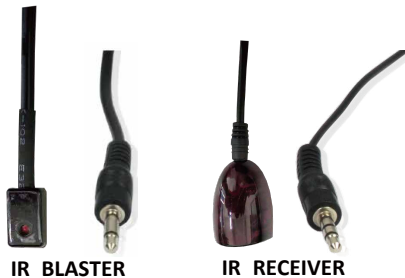

IR BLASTER

IR RECEIVER

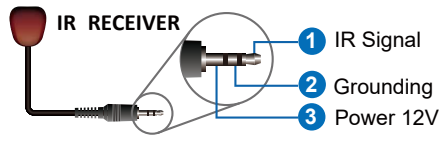
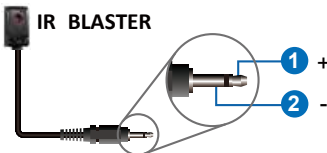

6. Rack Mounting Instruction

6.1 6U V2 Rack Mounting

This Controller can be mounted in a standard 6U V2 rack (Please contact your supplier for 6U V2 rack sale). The mounting steps are as follows:

Step 1: Use included screws to fix two mounting ears on the Controller, as shown in the figure below:

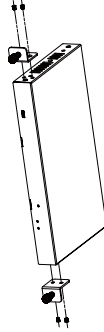

Step 2: Insert the Controller with mounting ears into a 6U V2 rack (up to 10 units can be installed vertically), as shown in the figure below:

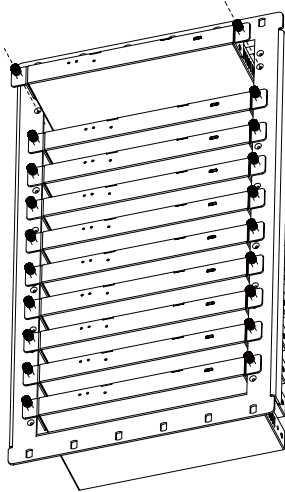

Step 3: Use screws to fix mounting ears on the rack to complete the mounting, as shown in the figure below:

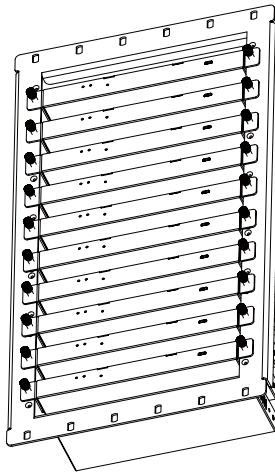

6.2 1U V2 Rack Mounting

This Controller also can be mounted in a standard 1U V2 rack. It is advised to install 2 units horizontally. The mounting steps are as follows:

Step 1: Use included screws to fix two 1U V2 rack panels on the Controller, and fix two rack panels on another Controller in the same way, as shown in the figure below:

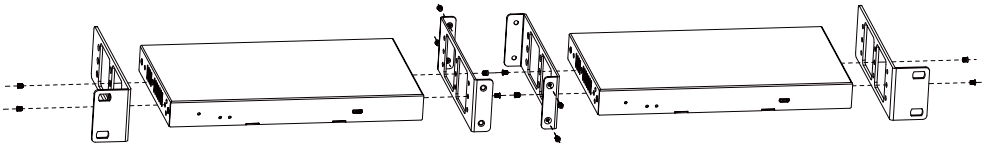

Step 2: Fasten screws between two 1U V2 rack panels, so that two Controllers are mounted in a 1U V2 rack, as shown in the figure below:

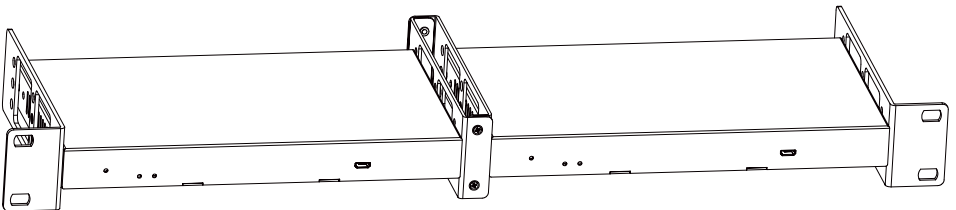

7. Web GUI Operation Guide

7.1 Preparation before Entering the System

You can use Controller's Web GUI to control all IP products at the Switch. The operation steps are as follows.

Step 1: Input the Controller's default IP address (Control LAN port: 192.168.6.100; Video LAN port: 169.254.8.100) or the URL (http://controller.local) into the Web browser address bar on the PC to enter the Web GUI login interface.



At first login, please select the initial username (admin), input the initial password (admin), and select the desired language on the above login interface. Then click "Login" to enter the password modification interface, as shown below.



Please set a six-digit password using letters or numbers, then use the new password to log in to the Web GUI.

For the first time, you need to set up the system, as shown in the following figure:

Welcome to AV over IP system setup guide. It leads you to create the system easily by following steps.
You can click the [Close] button to load an existing system in web page directly.

Close

Next

Step 2: Click the “Close” button to load an existing system in web page directly, or click “Next” button to go to the next step.

To setup AV over IP system, you need to set the IP management mode of the Video LAN domain. The IP management modes are:

Automatically managed by Controller Box.

This is the mode as factory default. The IP address assignments to Controller Box Video LAN, Encoders and Decoders will be managed by Controller Box firmware automatically. In this mode, there is no need to add router in the system on Video LAN domain.

DHCP mode.

This is the mode for system in which there is a DHCP router on Video LAN domain to assign IP addresses for Controller Box Video LAN, Encoders and Decoders. The router acts as a DHCP server. It's recommended to set the net mask of router to 255.255.0.0.

Static IP mode by manual settings.

This is the mode for system in case IP address resources can be assigned manually for Controller Box Video LAN, Encoders and Decoders. Reminders as below:

- a. The network settings of Controller Box Video LAN, Encoders and Decoders must be on the same subnet.
- b. It's recommended to set the net mask of Controller Box Video LAN, Encoders and Decoders to 255.255.0.0.

Close

Next

On this interface, you need to set the IP mode of Video LAN.

Mode 1: Automatically managed by Controller Box.

The IP addresses of the Video LAN port, Encoders and Decoders are assigned by the Controller automatically, and the connection method is as following.

Ultimo Dante Audio Encoder

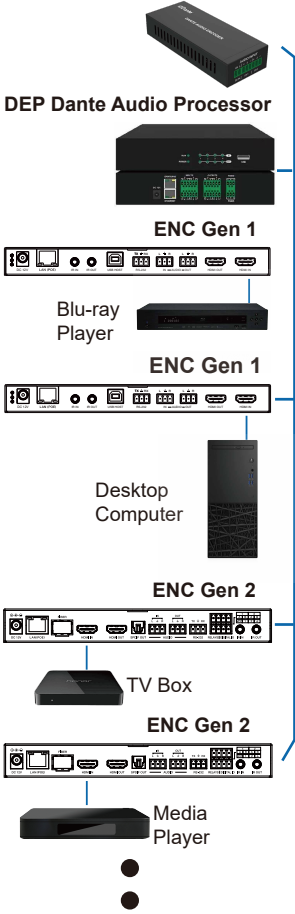

Ultimo Dante Audio Decoder

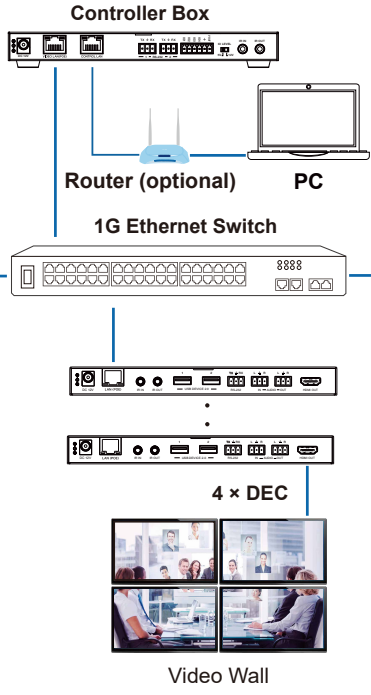
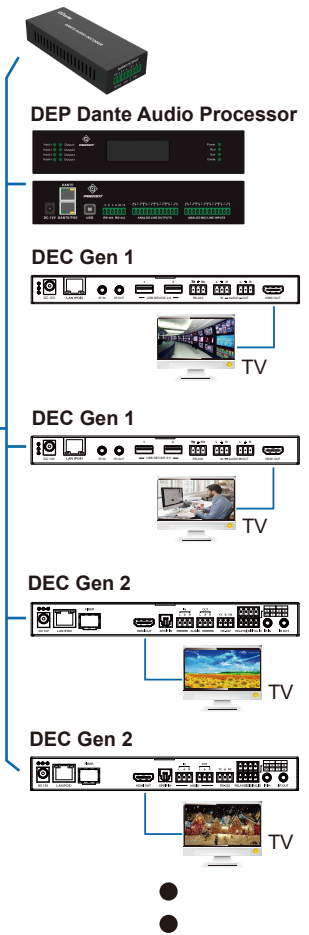

Step 3: Click the “Next” button and wait for the completion to enter the interface as shown in the figure below.

Now you can select to automatically add all following discovered Encoders and Decoders to system or just list them in the web page and you can add each of them to system manually.

Please click the [Search] button to search Encoders and Decoders in the system:

- Automatically add Encoders and Decoders to system.
- List all discovered Encoders and Decoders.

Close
Next

- If you select “Automatically add Encoders and Decoders to system”, and click the “Next” button to enter the Device page, the system starts to search for devices. All the connected devices will be searched and added into the system (presented in the Encoder/Decoder list) automatically, as shown below.

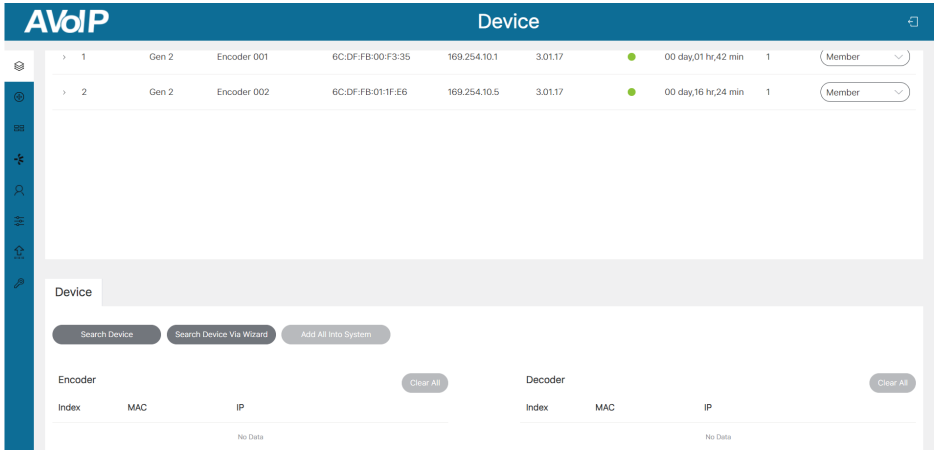

- If you select “List all discovered Encoders and Decoders”, and click the “Next” button to enter the Device page, the system starts to search for devices. All the connected devices will be searched and listed in the Device list. Then an inquiry box will pop up. If selecting “Yes”, all searched devices will be added into the system directly; If selecting “No”, you need to manually add them into the system by clicking the “Add” button behind each device one by one or clicking “Add All Into System”.

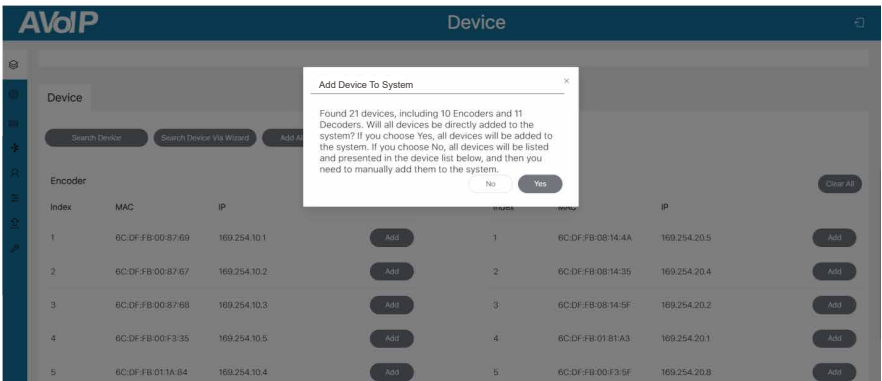
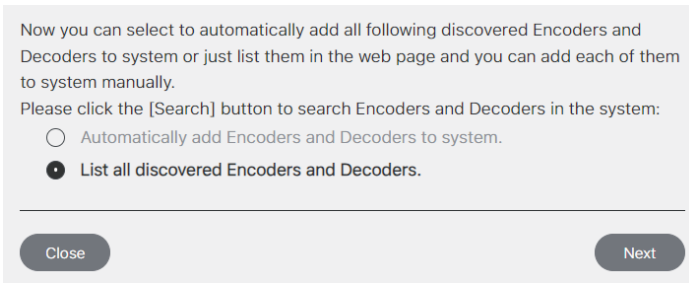

If you want to change the IP mode of Video LAN, you can click “Search Device Via Wizard” on the Device interface, and switch back to the IP mode select interface.

Mode 2: DHCP mode.

The IP addresses of the Video LAN port, Encoders and Decoders are assigned by the Router automatically, and the connection method is as following.

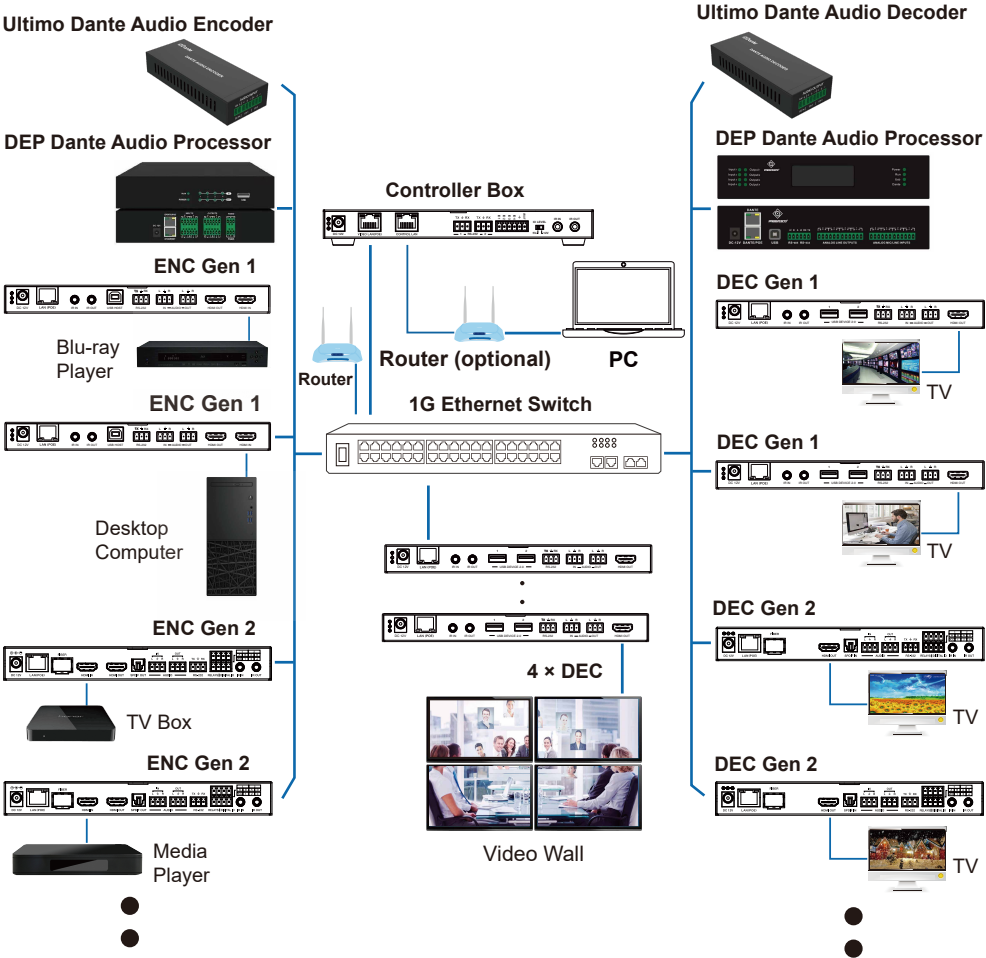

Select “DHCP Mode” on the interface shown below, and click “Next”.

To setup AV over IP system, you need to set the IP management mode of the Video LAN domain. The IP management modes are:

Automatically managed by Controller Box.

This is the mode as factory default. The IP address assignments to Controller Box Video LAN, Encoders and Decoders will be managed by Controller Box firmware automatically. In this mode, there is no need to add router in the system on Video LAN domain.

DHCP mode.

This is the mode for system in which there is a DHCP router on Video LAN domain to assign IP addresses for Controller Box Video LAN, Encoders and Decoders. The router acts as a DHCP server. It's recommended to set the net mask of router to 255.255.0.0.

Static IP mode by manual settings.

This is the mode for system in case IP address resources can be assigned manually for Controller Box Video LAN, Encoders and Decoders. Reminders are as below:

- The network settings of Controller Box Video LAN, Encoders and Decoders must be on the same subnet.
- It's recommended to set the net mask of Controller Box Video LAN, Encoders and Decoders to 255.255.0.0.

Close

Next

The rest of the steps are the same as the Mode 1 operation.

Mode 3: Static IP mode by manual settings.

The IP addresses of the Video LAN port, Encoders and Decoders are manually set by the user, and the connection method is as following.

Ultimo Dante Audio Encoder

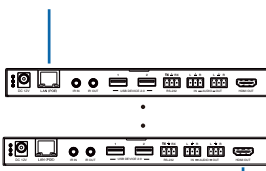
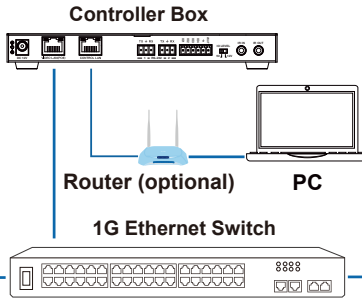
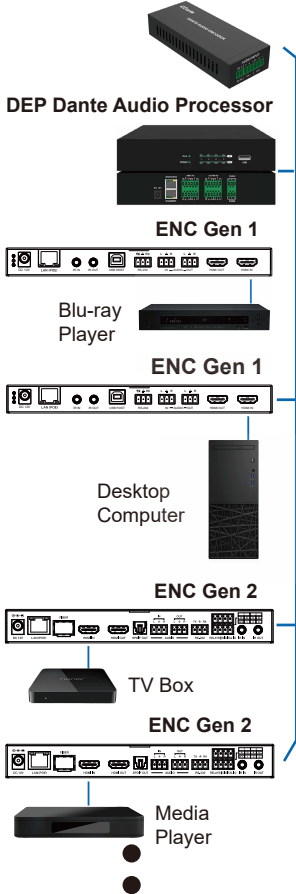

Video Wall

Ultimo Dante Audio Decoder

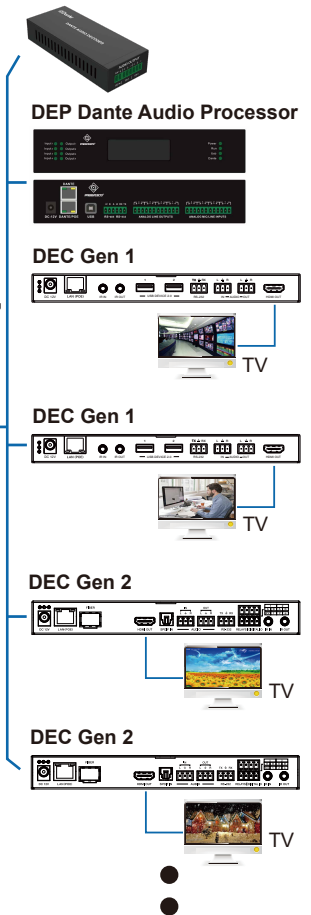

Select “Static IP mode by manual settings” on the interface shown below, and click “Next”.

To setup AV over IP system, you need to set the IP management mode of the Video LAN domain. The IP management modes are:

Automatically managed by Controller Box.

This is the mode as factory default. The IP address assignments to Controller Box Video LAN, Encoders and Decoders will be managed by Controller Box firmware automatically. In this mode, there is no need to add router in the system on Video LAN domain.

DHCP mode.

This is the mode for system in which there is a DHCP router on Video LAN domain to assign IP addresses for Controller Box Video LAN, Encoders and Decoders. The router acts as a DHCP server. It's recommended to set the net mask of router to 255.255.0.0.

Static IP mode by manual settings.

This is the mode for system in case IP address resources can be assigned manually for Controller Box Video LAN, Encoders and Decoders. Reminders as below:

- a. The network settings of Controller Box Video LAN, Encoders and Decoders must be on the same subnet.
- b. It's recommended to set the net mask of Controller Box Video LAN, Encoders and Decoders to 255.255.0.0.

Close Next

After entering the interface shown in the figure below, manually set the IP address, subnet mask and gateway of the Video LAN.

Controller Box Video LAN port Network Settings:

IP Address: 169 · 254 · 8 · 100

Subnet Mask: 255 · 255 · 0 · 0

Gateway: 169 · 254 · 8 · 1

Reminder:

Once Controller Box Video LAN network is set, the IP addresses of following discovered Encoders and Decoders will be assigned to the same domain with Controller Box Video LAN. Please click the [Next] button to set the IP address range of Encoders and Decoders.

Close Next

Note: The IP network domain of the Video LAN port must be different from that of the Control LAN port.

For example, we set the Video LAN network as shown in the above figure, and click the “Next“ button. After the progress reaches 100%, enter the interface as shown in the figure below.

Encoders and Decoders IP Addresses Range Settings:

Encoders IP Address From To

Decoders IP Address From To

Reminder:

To easily manage the IP addresses of Encoders and Decoders, it's strongly recommended that you can set the IP addresses of Encoders and Decoders to different segments correspondingly. For example:

Encoders IP address from 169.254.10.1 to 169.254.12.255

Decoders IP address from 169.254.20.1 to 169.254.22.255

On this interface, you can set the IP address range of Encoders and Decoders.

After the setting is complete, click the “Next” button to enter the interface as shown in the figure below.

Now you can select to automatically add all following discovered Encoders and Decoders to system or just list them in the web page and you can add each of them to system manually.

Please click the [Search] button to search Encoders and Decoders in the system:

Automatically add Encoders and Decoders to system.

List all discovered Encoders and Decoders.

The rest of the steps are the same as the Mode 1 operation.

7.2 Functions and Operation

7.2.1 Device

On this page, you can click the Encoder/Decoder tab to check the information of the Encoders and Decoders in the system, such as ID, Type, Name, MAC address, IP address, Firmware version, Online/Offline Status, Up Time, RX Link, Member/Source. Besides, you can configure each Encoder/Decoder after clicking the drop-down icon on the left side of ID.

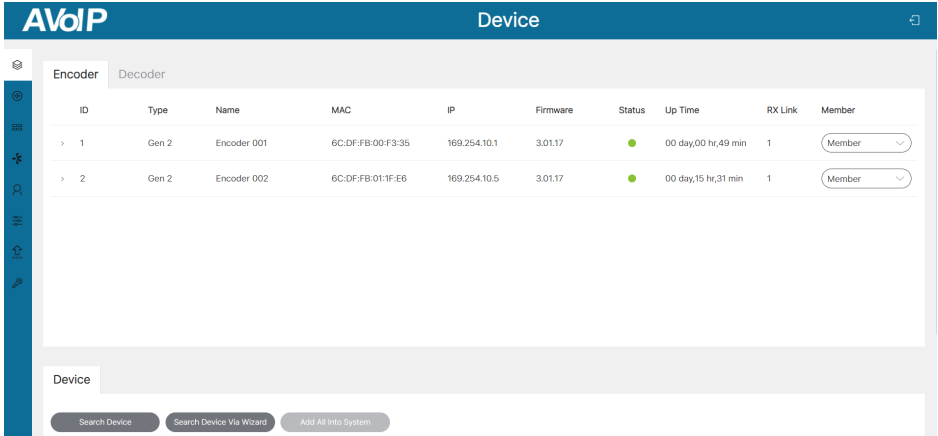

The screenshot shows the AVoIP Device management interface. At the top, there is a blue header with the AVoIP logo and the word "Device". Below the header, there are two tabs: "Encoder" (selected) and "Decoder". The main area contains a table with the following columns: ID, Type, Name, MAC, IP, Firmware, Status, Up Time, RX Link, and Member. There are two rows of data, both for Gen 2 Encoders. Each row has a drop-down arrow on the left side of the ID column and a "Member" button with a drop-down arrow on the right side. Below the table, there is a "Device" section with three buttons: "Search Device", "Search Device Via Wizard", and "Add All Into System".

ID	Type	Name	MAC	IP	Firmware	Status	Up Time	RX Link	Member
> 1	Gen 2	Encoder 001	6C:DF:FB:00:F3:35	169.254.10.1	3.01.17	●	00 day,00 hr,49 min	1	Member
> 2	Gen 2	Encoder 002	6C:DF:FB:01:F3:E6	169.254.10.5	3.01.17	●	00 day,15 hr,31 min	1	Member

Note: The controller can simultaneously control two types of Encoders and Decoders (distinguished by Gen 1/2) in one system.

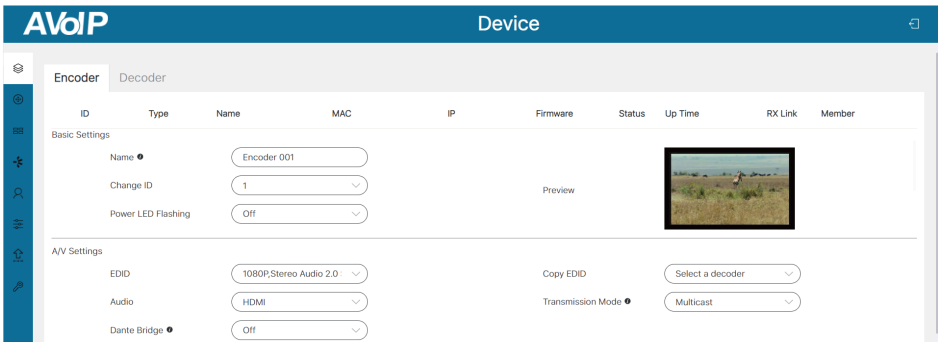

The screenshot shows the AVoIP Device configuration interface for an Encoder. At the top, there is a blue header with the AVoIP logo and the word "Device". Below the header, there are two tabs: "Encoder" (selected) and "Decoder". The main area is divided into "Basic Settings" and "A/V Settings". In the "Basic Settings" section, there are three fields: "Name" (Encoder 001), "Change ID" (1), and "Power LED Flashing" (Off). In the "A/V Settings" section, there are four fields: "EDID" (1080P: Stereo Audio 2.0), "Audio" (HDMI), "Dante Bridge" (Off), and "Copy EDID" (Select a decoder). There is also a "Transmission Mode" field set to "Multicast". A "Preview" button is located to the right of the "Basic Settings" section, and a video preview window is shown to the right of the "A/V Settings" section.

Encoder Configuration

Basic Settings

① **Name:** The name of the Encoder can be changed. (The maximum length is 16 characters. Special characters are not supported.)

Note: The Dante AV-A™ device can only be renamed here. The characters “ ”, “ _ ” and “ ’ ” that are not allowed for showing in Dante page will be replaced with “ - ”. After renaming, the new name will be refreshed synchronously on the Dante page.

② **Change ID:** The ID of the Encoder can be set. (ID range:1-762)

Note: Both ID and name can not be duplicated.

③ **Power LED Flashing:** Click the drop-down menu to select the power LED flash status.

Off: The front panel power LED is steady on after flash status is turned off.

Flashing: The front panel power LED flashes.

Flashing 90s then off: The front panel power LED is steady on after flashing for 90s.

④ **Preview:** The preview of the Encoder.

A/V Settings

① **EDID:** Click the drop-down menu to select the EDID for the Encoder.

② **Copy EDID:** Click the drop-down menu to select a Decoder for EDID copy.

③ **Audio:** Click the drop-down menu to select the audio source (HDMI/Analogue).

(1) When HDMI is selected, Encoder HDMI input is the audio source for Encoder HDMI output and Decoder audio output.

(2) When Analogue is selected, Encoder audio input is the audio source for Encoder HDMI output and Decoder audio output.

④ **Transmission Mode:** Click the drop-down menu to select the transmission mode (Multicast/Unicast).

⑤ **Dante Bridge:** Click the drop-down menu to select On/Off to turn on/off the Dante bridge function. When set to “On”, the Encoder will receive the audio from Dante network, and then bridge it to the AV over IP system to be the audio source for the Decoders without Dante function.

Note: The Encoder HDMI loop output keeps outputting the native audio source, and will not be influenced by the setting here.

The screenshot shows the AVoIP Device configuration page. The top navigation bar is blue with 'AVoIP' on the left and 'Device' on the right. Below the navigation bar, there are two tabs: 'Encoder' (selected) and 'Decoder'. The main content area is a configuration table with columns: ID, Type, Name, MAC, IP, Firmware, Status, Up Time, RX Link, and Member. The table is currently empty. Below the table, there are two sections: 'Network Settings' and 'Dual LAN Port Settings'. Each section has an 'Apply' button. The 'Network Settings' section includes: IP Mode (Static), IP Address (169.254.10.1), Subnet Mask (255.255.0.0), and Gateway (169.254.1.1). The 'Dual LAN Port Settings' section includes: Dante VLAN IP Mode (DHCP), Dante VLAN IP Address (192.168.134.05), Dante VLAN Subnet Mask (255.255.0.0), Dante VLAN Gateway (192.168.0.1), and Dante VLAN (Off).

Network Settings

① **IP Mode:** Click the drop-down menu to set the IP mode (Static/DHCP).

② **IP Address:** The IP address of the Encoder.

③ **Subnet Mask:** The Subnet Mask of the Encoder.

④ **Gateway:** The Gateway of the Encoder.

Note:

(1) If the IP mode is set to “Static”, you can manually set the IP Address, Subnet Mask and Gateway as required. Then click “Apply”, the Encoder will immediately reboot to take effect.

(2) If the IP mode is set to “DHCP”, it will search and be filled with the IP Address assigned by the router automatically.

(3) If the Encoder is actually alive in the system but with incorrect network segment settings, even though the Encoder is offline, its network settings including IP address can be changed and set.

Dual LAN Port Settings

- ① **Dante VLAN IP Mode:** The Dante VLAN IP mode (Static/DHCP) of the Encoder.
- ② **Dante VLAN IP Address:** The Dante VLAN IP address of the Encoder.
- ③ **Dante VLAN Subnet Mask:** The Dante VLAN Subnet Mask of the Encoder.
- ④ **Dante VLAN Gateway:** The Dante VLAN Gateway of the Encoder.
- ⑤ **Dante VLAN:** Click the drop-down menu to select On/Off to turn on/off the Dante VLAN.
- ⑥ **Dante VLAN Tag(1~4095):** The Dante VLAN tag of the Encoder.

The screenshot shows the AVoIP Device configuration page. The top navigation bar is blue with 'AVoIP' on the left and 'Device' on the right. Below the navigation bar, there are tabs for 'Encoder' and 'Decoder'. The 'Encoder' tab is active. A table with columns: ID, Type, Name, MAC, IP, Firmware, Status, Up Time, RX Link, Member is visible. Below the table, there are sections for 'Hardware Usage' and 'RS-232 Settings'. The 'Hardware Usage' section includes: CEC Pin Usage (ARC/eARC), ARC/eARC Return From (None), Capability of Amplifier On HDMI IN Port (None), and Network Interface Usage (Copper). The 'RS-232 Settings' section includes: RS-232 Command Relay (Off), Parity (None), Baud Rate (115200), Data Bits (8 bit), and Stop Bits (1 bit). At the bottom, there are buttons for 'Search Device', 'Search Device Via Wizard', and 'Add All Into System'.

Hardware Usage

- ① **CEC Pin Usage:** Click the drop-down menu to set the CEC pin usage (ARC/eARC/CEC/Off). After switching, the Encoder will immediately reboot to take effect.
- ② **ARC/eARC Return From:** Click the drop-down menu to select a Decoder for ARC/eARC audio return.

Note: Only Encoders with ARC/eARC function can perform this setting.

- ③ **Capability of Amplifier On HDMI IN Port:** It indicates the ARC capability supported by the Amplifier.

Note: When the amplifier on HDMI IN port only supports ARC, and the TV connected to the Decoder only supports eARC, the setting of “eARC Down grade To ARC” on the Decoder needs to set “On” to achieve the audio path working normally. The eARC downgrade of the Decoder will also apply onto all Encoders that select this Decoder.

- ④ **Network Interface Usage:** Click the drop-down menu to set the network port (Fiber/Copper).

Note: Only Encoders that integrate Copper and Fiber ports can perform this setting.

RS-232 Settings

- ① **RS-232 Command Relay:** Click the drop-down menu to select On/Off to turn on/off the RS-232 command relay function.
- ② **Parity:** Click the drop-down menu to set the parity.

- ③ **Baud Rate:** Click the drop-down menu to set the baud rate.
 - ④ **Data Bits:** Click the drop-down menu to set the data bits.
 - ⑤ **Stop Bits:** Click the drop-down menu to set the stop bits.
- After setting, click “Apply” to take effect.

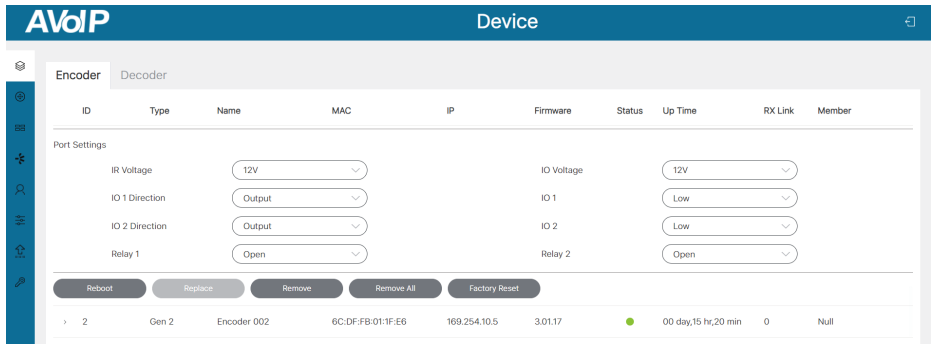

Port Settings

- ① **IR Voltage:** Click the drop-down menu to select the 5V/12V IR voltage.
- ② **IO Voltage:** Click the drop-down menu to select the 5V/12V IO voltage.
- ③ **IO 1 Direction:** Click the drop-down menu to set the IO 1 direction (Input/Output).
- ④ **IO 1:** Click the drop-down menu to set the IO 1 level (Low/High).
- ⑤ **IO 2 Direction:** Click the drop-down menu to set the IO 2 direction (Input/Output).
- ⑥ **IO 2:** Click the drop-down menu to set the IO 2 level (Low/High).
- ⑦ **Relay 1:** Click the drop-down menu to select Open/Close Relay 1.
- ⑧ **Relay 2:** Click the drop-down menu to select Open/Close Relay 2.

Reboot: Click the Reboot button to reboot the Encoder.

Replace: Click to replace the offline Encoder (which is in the system) with an online Encoder (which is not in the system).

For example, follow steps below to replace Encoder 001 with Encoder 006:

Step 1. Unplug the network cable of Encoder 001 to make it be offline. (Using external power supply.)

Step 2. Connect Encoder 006 to the system.

Step 3. Click the Replace button, which is clickable after Encoder 001 is set to be offline. Then a window will pop up, as shown below. At this moment, click “Scan for Devices” to search devices. After Encoder 006 is searched, select it and click “Replace” to replace Encoder 001.

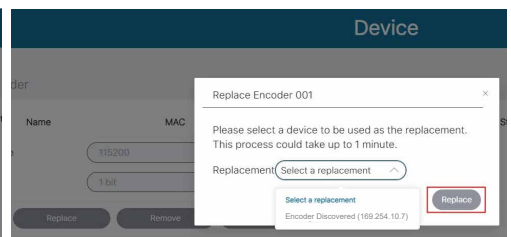
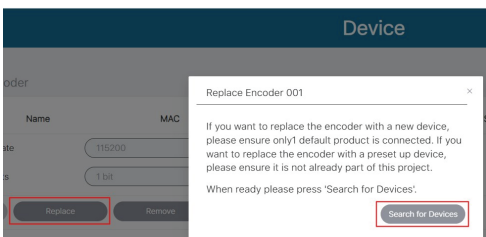

Remove: Click the Remove button to remove the Encoder from the system.

Remove All: Click this button to remove all Encoders from the system.

Factory Reset: Click this button to restore the Encoder to factory settings.

Decoder Configuration

The screenshot shows the AVoIP Device configuration interface. At the top, there is a blue header with the AVoIP logo and the word "Device". Below the header, there are two tabs: "Encoder" and "Decoder", with "Decoder" selected. A table lists two decoder entries:

ID	Type	Name	MAC	IP	Firmware	Status	Up Time	Source
1	Gen 2	Decoder 001	6C:DF:FB:00:F3:52	169.254.20.2	3.01.17	●	00 day,15 hr,35 min	Encoder 001
2	Gen 2	Decoder 002	6C:DF:FB:01:1F:EC	169.254.20.3	3.01.17	●	00 day,15 hr,35 min	Encoder 002

Below the table, there is a "Device" section with three buttons: "Search Device", "Search Device Via Wizard", and "Add All Into System".

Basic Settings

① **Name:** The name of the Decoder can be changed. (The maximum length is 16 characters. Special characters are not supported.)

Note: The Dante AV-A™ device can only be renamed here. The characters “ ”, “_” and “ ’ ” that are not allowed for showing in Dante page will be replaced with “-”. After renaming, the new name will be refreshed synchronously on the Dante page.

② **Change ID:** The ID of the Decoder can be set. (ID range:1-762)

Note: Both ID and name can not be duplicated.

③ **Power LED Flashing:** Click the drop-down menu to select the power LED flash status.

Off: The front panel power LED is steady on after flash status is turned off.

Flashing: The front panel power LED flashes.

Flashing 90s then off: The front panel power LED is steady on after flashing for 90s.

The screenshot shows the AVoIP Device configuration interface, specifically the "Basic Settings" section for a decoder. The "Decoder" tab is selected, and the table from the previous screenshot is visible at the top. Below the table, the "Basic Settings" section includes:

- Name:** A text input field containing "Decoder 001".
- Change ID:** A dropdown menu set to "1".
- Power LED Flashing:** A dropdown menu set to "Off".
- Hotkey Setting:** A button labeled "Setting".
- Preview:** A small video preview window showing a scene with people.

At the bottom, there is an "AV Settings" section which is currently empty.

④ **Hotkey Setting:** You can set up to 20 sets of hotkeys for Decoders. Click the “Setting” button to pop up the Hotkey Setting window, as shown in the following figure. Click the “+” icon to create a new hotkey, and then set the ID, function key, toggle key, action, signal/target separately. Click the “-” icon to delete the corresponding hotkey settings.

Index	ID	Function key	Toggle key	Action	Signal/Target	Delete
1	1	Left Ctrl	1	Subscribe From	Encoder 002	—
2	2	Left Ctrl	2	Share Source To	Decoder 003	—
3						+

For example:

After completing the hotkey settings for ID 1 and 2, as shown in the above figure. Press the function key “Left Ctrl” and toggle key “1” simultaneously 3 times in 1 second to execute the action “Subscribe From” to the signal “Encoder 002”, that is, switch the signal source of Decoder 001 to Encoder 002. If press the function key “Left Ctrl” and toggle key “2” simultaneously 3 times in 1 second, the action “Share Source To” can be executed to the target “Decoder 003”, that is, the current signal source “Encoder 002” of Decoder 001 will be switched to Decoder 003 at the same time.

Notes:

- (1) Only Encoders and Decoders that support USB KVM functionality can perform hotkey settings.
- (2) The toggle keys are limited to the keys within the red box on the keyboard, as shown in the following figure.



⑤ **Preview:** The preview of the Decoder.

Besides, you can click the drop-down menu of “Source” on the Decoder list to select signal source for the Decoder.

AVoIP
Device

Encoder
Decoder

ID	Type	Name	MAC	IP	Firmware	Status	Up Time	Source
AV Settings								
Video Output		On			Video Mute		Off	
Rotation & Flip		Rotate 0°			Scaling		Bypass	
Show ID OSD		Off			Output Mode		Matrix	
Transmission Mode		Multicast			Audio Source On Outputs		Dante	
Dante Bridge		Off						
Locked Signal Routing								
Video		Encoder			Audio		Encoder	

A/V Settings

- ① **Video Output:** Click the drop-down menu to select On/Off to turn on/off the video output.
- ② **Video Mute:** Click the drop-down menu to select On/Off to mute/unmute the video output.
- ③ **Rotation & Flip:** Click the drop-down menu to select Rotate 0°/90°/180°/270° to rotate the image, or select Flip Horizontal/Vertical to flip the image.
- ④ **Scaling:** Click the drop-down menu to set the video output scaling resolution.
- ⑤ **Show ID OSD:** Click the drop-down menu to select On/Off to turn on/off the ID OSD display.
- ⑥ **Output Mode:** In the Video Wall mode, you can click the drop-down menu to select Matrix or Video Wall as the output mode. While, in the Matrix mode, this option cannot be selected.
- ⑦ **Transmission Mode:** Click the drop-down menu to select the transmission mode (Multicast/Unicast).
- ⑧ **Audio Source On Outputs:** Click the drop-down menu to select the audio source for Decoder HDMI output and analog audio output.
Native: Use AV over IP system audio stream as the audio source.
Dante: Use Dante audio from Dante network as the audio source.
In case of setting the audio routing of the Decoder in the Dante page, “Dante” must be selected.
- ⑨ **Dante Bridge:** Click the drop-down menu to select On/Off to turn on/off the Dante bridge function. When set to “On”, the Decoder will bridge the audio stream which the Decoder subscribes into Dante network, so that the audio stream in AV over IP system can be used for Dante devices in Dante network.

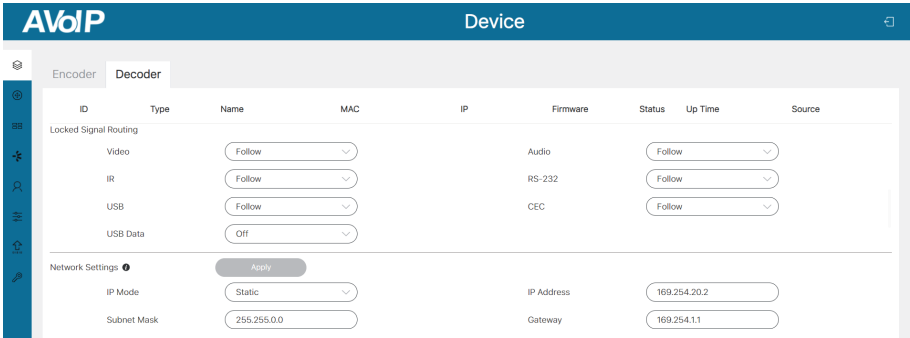

Locked Signal Routing

Different signals can be independently routed between Encoders and Decoders, including Video, Audio, IR, RS-232, USB and CEC; When clicking the drop-down menu and selecting “Follow”, the corresponding signal comes from the current Encoder.

For example, follow steps below to change the video routing of Decoder 001 to be from Encoder 002.

Step 1. Click the drop-down menu of Video to select “Encoder 002”.

Locked Signal Routing	
Video	Encoder 002
IR	Follow
USB	Encoder 001
USB Data	Off

Step 2. Switch to the Matrix page and you will see a red frame on Decoder 001.

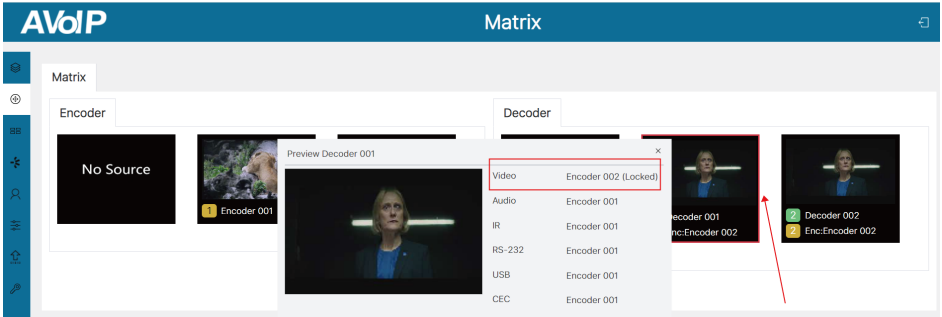

Step 3. Double-click the preview image of Decoder 001 to check the current settings. The video source has been locked to Encoder 002, while other signals still follow Encoder 001, as shown in the figure above. And you can change the source of audio, IR, RS-232, USB and CEC in the same way.

In addition, you can click the drop-down menu of USB Data to select On/Off to turn on/off the USB data.

Network Settings			
IP Mode	Static	IP Address	169.254.20.2
Subnet Mask	255.255.0.0	Gateway	169.254.1.1

Network Settings

- ① **IP Mode:** Click the drop-down menu to set the IP mode (Static/DHCP).
- ② **IP Address:** The IP address of the Decoder.
- ③ **Subnet Mask:** The Subnet Mask of the Decoder.
- ④ **Gateway:** The Gateway of the Decoder.

Note:

- (1) If the IP mode is set to "Static", you can manually set the IP Address, Subnet Mask and Gateway as required. Then click "Apply", the Decoder will immediately reboot to take effect.
- (2) If the IP mode is set to "DHCP", it will search and be filled with the IP Address assigned by the router automatically.
- (3) If the Decoder is actually alive in the system but with incorrect network segment settings, even though the Decoder is offline, its network settings including IP address can be changed and set.

The screenshot shows the 'Decoder' configuration page under 'Dual LAN Port Settings'. It features a table with columns: ID, Type, Name, MAC, IP, Firmware, Status, Up Time, and Source. Below the table are several settings:

- Dual LAN Port Settings:** An 'Apply' button is present.
- Dante VLAN IP Mode:** A dropdown menu set to 'DHCP'.
- Dante VLAN IP Address:** A text input field containing '0.0.0.0'.
- Dante VLAN Subnet Mask:** A text input field containing '0.0.0.0'.
- Dante VLAN Gateway:** A text input field containing '0.0.0.0'.
- Dante VLAN:** A dropdown menu set to 'Off'.
- Dante VLAN Tag(1~4095):** A text input field containing '10'.

Dual LAN Port Settings

- ① **Dante VLAN IP Mode:** The Dante VLAN IP mode (Static/DHCP) of the Decoder.
- ② **Dante VLAN IP Address:** The Dante VLAN IP address of the Decoder.
- ③ **Dante VLAN Subnet Mask:** The Dante VLAN Subnet Mask of the Decoder.
- ④ **Dante VLAN Gateway:** The Dante VLAN Gateway of the Decoder.
- ⑤ **Dante VLAN:** Click the drop-down menu to select On/Off to turn on/off the Dante VLAN.
- ⑥ **Dante VLAN Tag(1~4095):** The Dante VLAN tag of the Decoder.

The screenshot shows the 'Decoder' configuration page under 'Hardware Usage'. It features a table with columns: ID, Type, Name, MAC, IP, Firmware, Status, Up Time, and Source. Below the table are several settings:

- Hardware Usage:**
- CEC Pin Usage:** A dropdown menu set to 'ARC/eARC'.
- Sink Capability:** A dropdown menu set to 'ARC/eARC'.
- Audio Return Path:** A dropdown menu set to 'ARC/eARC'.
- eARC Downgrade To ARC:** A dropdown menu set to 'Off'.
- Network Interface Usage:** A dropdown menu set to 'Copper'.
- RS-232 Settings:** An 'Apply' button is present.
- RS-232 Command Relay:** A dropdown menu set to 'Off'.
- Parity:** A dropdown menu set to 'None'.
- Baud Rate:** A dropdown menu set to '115200'.
- Data Bits:** A dropdown menu set to '8 bit'.
- Stop Bits:** A dropdown menu set to '1 bit'.

Hardware Usage

- ① **CEC Pin Usage:** Click the drop-down menu to set the CEC pin usage (ARC/eARC/CEC/Off). After switching, the Decoder will immediately reboot to take effect.
- ② **Sink Capability:** It indicates the ARC capability (eARC/ARC/None) supported by the TV.
- ③ **Audio Return Path:** Click the drop-down menu to select the audio return path (ARC/S/PDIF).
- ④ **eARC Downgrade To ARC:** When the amplifier on HDMI IN port only supports ARC, and the TV connected to the Decoder only supports eARC, the setting of “eARC Downgrade To ARC” needs to set “On” to achieve the audio path working normally. The eARC downgrade of the Decoder will also apply onto all Encoders that select this Decoder.
Note: The settings of “Sink Capability”, “Audio Return Path” and “eARC Downgrade To ARC” are available only for Decoders that support ARC/eARC.
- ⑤ **Network Interface Usage:** Click the drop-down menu to set the network port (Fiber/Copper).
Note: Only Decoders that integrate Copper and Fiber ports can perform this setting.

RS-232 Settings

① **RS-232 Command Relay:** Click the drop-down menu to select On/Off to turn on/off the RS-232 command relay function.

Note: When the RS-232 command relay function is turned on, the Decoder's locked signal routing function is disabled.

② **Parity:** Click the drop-down menu to set the parity.

③ **Baud Rate:** Click the drop-down menu to set the baud rate.

④ **Data Bits:** Click the drop-down menu to set the data bits.

⑤ **Stop Bits:** Click the drop-down menu to set the stop bits.

After setting, click "Apply" to take effect.

The screenshot shows the AVoIP Device configuration interface. The top navigation bar is blue with 'AVoIP' on the left and 'Device' on the right. Below the navigation bar, there are two tabs: 'Encoder' and 'Decoder'. The 'Decoder' tab is active. The main content area is titled 'Port Settings' and contains several configuration options: IR Voltage (12V), IO 1 Direction (Output), IO 2 Direction (Output), Relay 1 (Open), and Relay 2 (Open). There are also buttons for Reboot, Replace, Remove, Remove All, and Factory Reset. At the bottom, there is a table with one row showing a device with ID 2, Type Gen 2, Name Decoder 002, MAC 6C:DF:FB:01:1F:EC, IP 169.254.20.3, Firmware 3.01.17, Status (green dot), Up Time 00 day,15 hr,32 min, and Source Encoder 001. Below the table are buttons for Search Device, Search Device Via Wizard, and Add All Into System.

Port Settings

① **IR Voltage:** Click the drop-down menu to select the 5V/12V IR voltage.

② **IO Voltage:** Click the drop-down menu to select the 5V/12V IO voltage.

③ **IO 1 Direction:** Click the drop-down menu to set the IO 1 direction (Input/Output).

④ **IO 1:** Click the drop-down menu to set the IO 1 level (Low/High).

⑤ **IO 2 Direction:** Click the drop-down menu to set the IO 2 direction (Input/Output).

⑥ **IO 2:** Click the drop-down menu to set the IO 2 level (Low/High).

⑦ **Relay 1:** Click the drop-down menu to select Open/Close Relay 1.

⑧ **Relay 2:** Click the drop-down menu to select Open/Close Relay 2.

Reboot: Click the Reboot button to reboot the Decoder.

Replace: Click to replace the offline Decoder (which is in the system) with an online Decoder (which is not in the system). The method to replace Decoders is the same as the Encoder replacement.

Remove: Click the Remove button to remove the Decoder from the system.

Remove All: Click this button to remove all Decoders from the system.

Factory Reset: Click this button to restore the Decoder to factory settings.

Device

- ① **Search Device:** Click this button to search devices which are not in the system.
- ② **Search Device Via Wizard:** Click this button to switch back to the IP mode select interface and follow the Wizard to set up the system.
- ③ **Add All Into System:** Click this button to add all searched devices into the system, then the devices will be listed on the Encoder/Decoder list.

7.2.2 Matrix

Matrix Switching Function

- ① Left-click the Encoder and drag it to Decoder, then release the mouse to realize one-to-one switching.

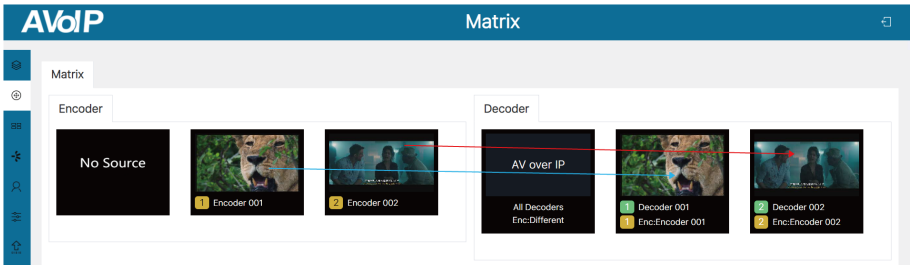

- ② Left-click the Encoder and drag it to All Decoders, then release the mouse to realize one-to-all switching.

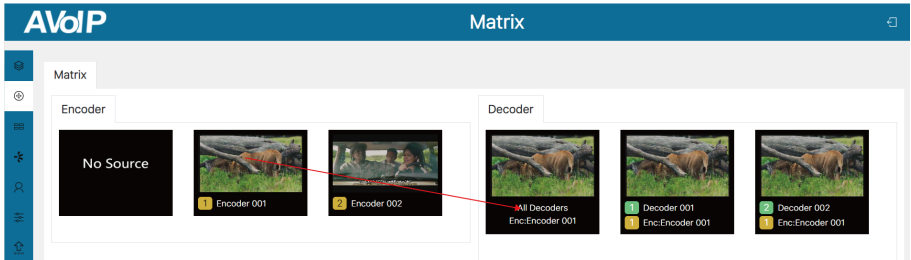

Note: Encoders can only be dragged to the Decoder preview of the same type to achieve signal switching. For one-to-all switching, only the Decoders of the same type will output the same signal.

- ③ Left-click the Encoder and drag it to multiple Decoders, then release the mouse to realize one-to-many switching.

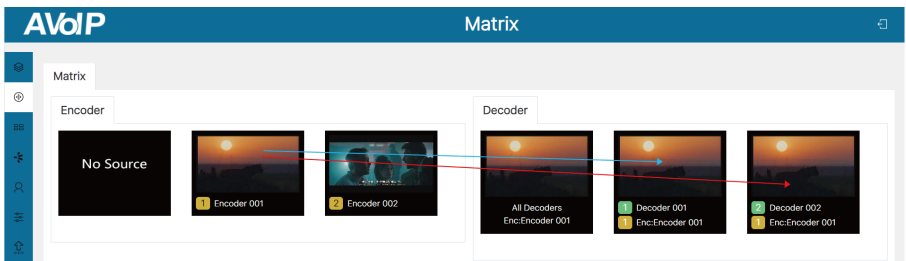

Disconnect the Signal Connection

Click the “No Source” image in the Encoder preview list with the left mouse button and drag it to the Decoder preview image. Release the mouse to disconnect the Decoder from the signal source, and the corresponding display will show “No Source”. If you drag the “No Source” image to “All Decoders” and release the mouse, a prompt window will pop up as shown below. Manually enter “YES” and then click “Yes”, all Decoder signal sources in matrix mode will be disconnected. After that, you need to configure Encoders for Decoders again. Therefore, please proceed with caution.

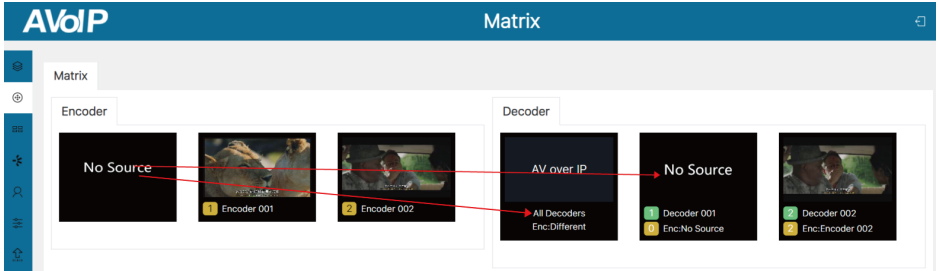

Tips

You attempt to change All Decoders to "No Source", this will disconnect all connections of all decoders in matrix mode from their sources. After that, you need to configure each decoder subscribing from source encoder one by one again to "restore" all connection settings. Are you sure to continue? If yes, please type "YES" in capitals in below edit box and then click Yes button to apply. Otherwise, click No or Close button to leave with nothing changed.

Yes

No

Signal Routing Query

Double-click the preview image of Decoder to check the Video/Audio/IR/RS-232/USB corresponding relationship between the Encoder and Decoder.

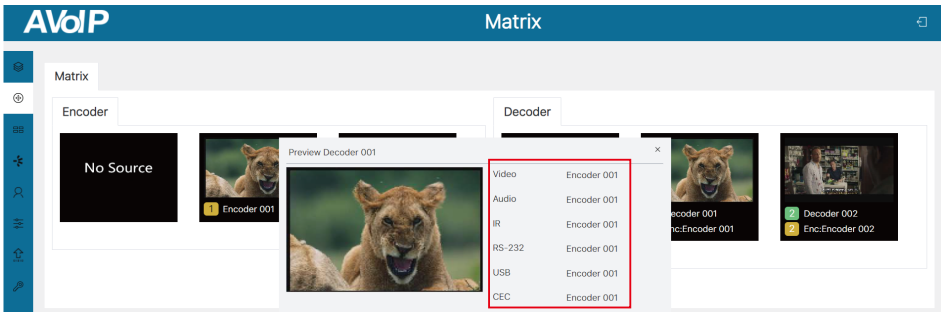

7.2.3 Video Wall

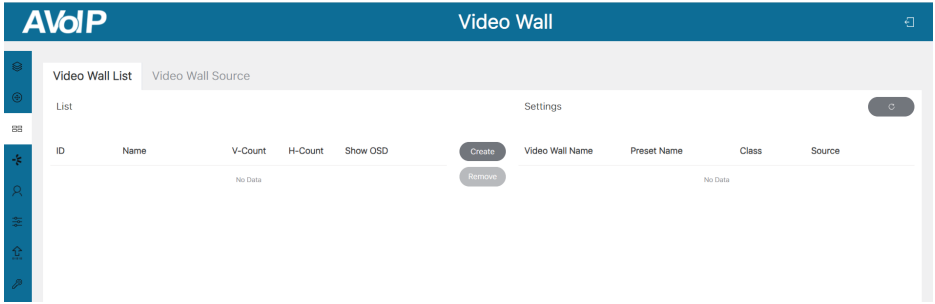

Video Wall Creation

On the Video Wall List interface of this page, you can create and configure video wall as required. Please follow below steps to create and configure a video wall.

Step 1: Click “Create”, a pop-up window will be shown as below.

Create a new Video Wall ×

Video Wall ID

Video Wall Name

Row Number

Column Number

You can set the Video Wall ID, Video Wall Name, Row Number and Column Number. Then click “Go” to create the video wall.

Note:

- (1) Up to 9 video walls can be created.
- (2) The video wall name can be changed after the video wall is created.

Step 2: Select the video wall that you want to configure, then click “Assign Decoder” at the bottom of the Video Wall List interface to enter the Decoder assignment interface. Click each screen to select the corresponding Decoder device, then click “Apply” to take effect.

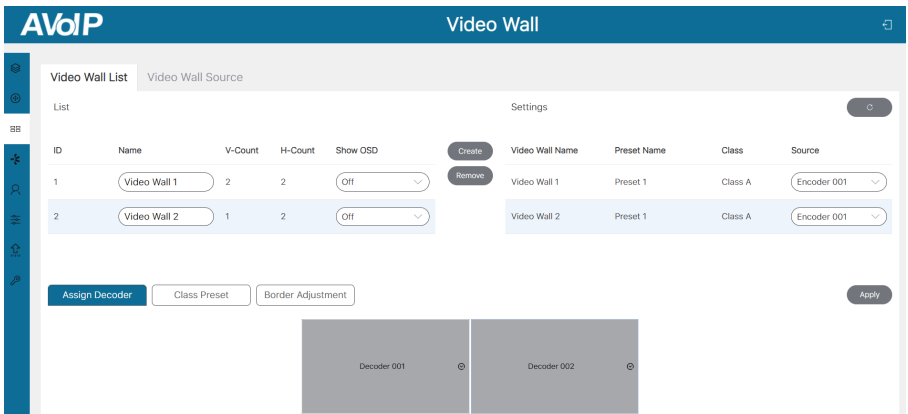

Note: A Decoder can only be assigned to one video wall.

Step 3: Click “Class Preset” to enter the class configuration preset interface, then click each screen to select the corresponding Class as required (the same class name will form a video wall, you can create a regular or irregular video wall by Class Preset). Then click “Apply” to take effect.

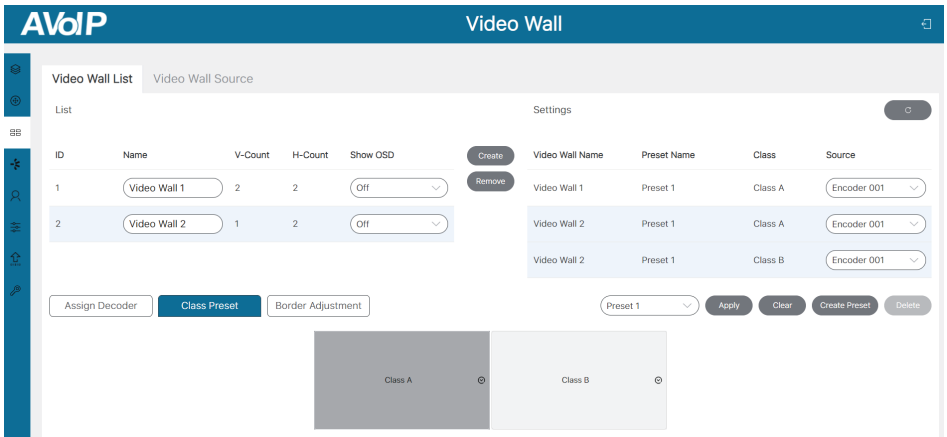

The preset name can be changed with letters or numbers (max length: 16 characters). Besides, you can click the drop-down menu icon behind the preset name to switch different presets (the selected preset will be high-lighted in Settings), click “Create Preset” to create up to 9 configurations for different application scenarios, click “Clear” to clear and reset video wall class settings, or click “Delete” to delete the current class preset from the system. After setting, you should click “Apply” to take effect.

Step 4: Click “Border Adjustment” to enter the Border Adjustment interface, then click the drop-down menu to set the Base Width, Image Width, Base Height and Image Height. Finally, click “Apply” to adjust the border of each Decoder, or click “Apply All” to adjust the borders of all Decoders.

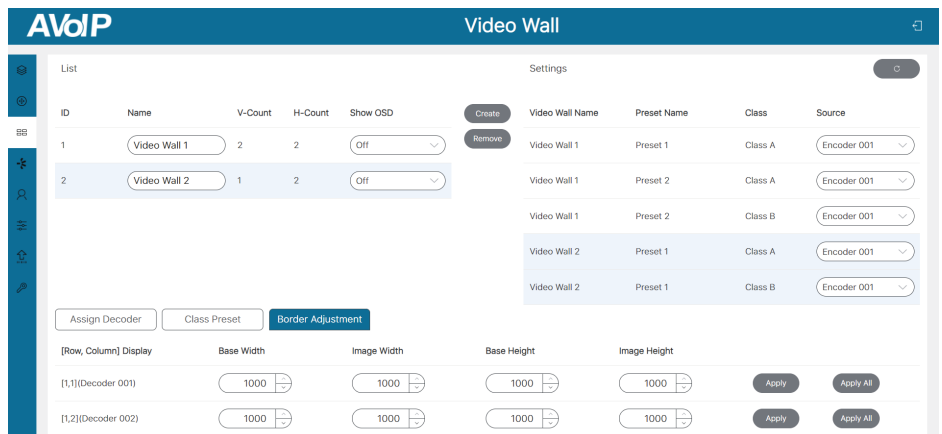

Note: The Base value cannot be more than 2 times the Image value.

Video Wall Source

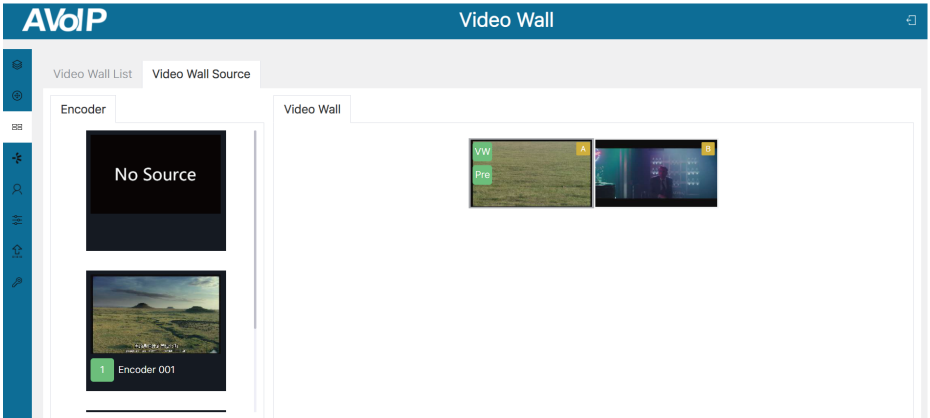

After the video wall is created and configured, you can click the Video Wall Source tab to check the video wall preview, video wall class, and its corresponding signal source. You can click the “VW” icon on the preview of video wall to switch different video walls, or click the “Pre” icon to switch different presets.

Besides, you can directly drag Encoders to the video wall to change signal sources. If you drag “No Source” to the video wall, then the signal source of the video wall will be disconnected, and the corresponding windows will display “No Source”.

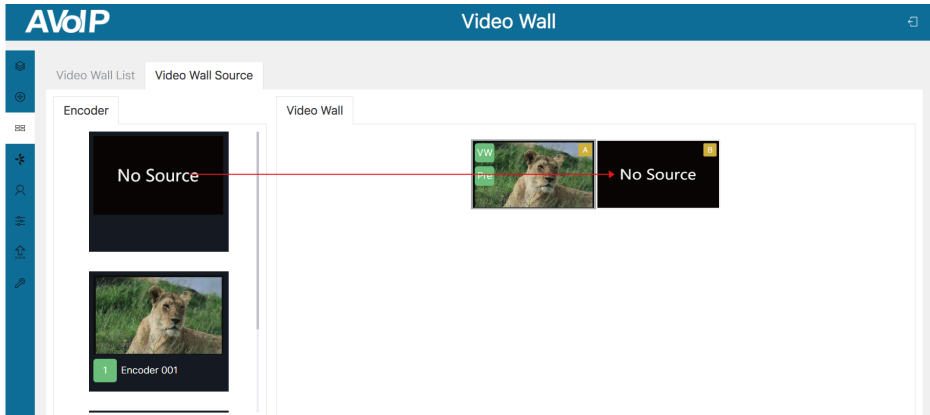

- Note:**
- (1) If the Encoder is offline, it can't be dragged to the matrix of video wall.
 - (2) Only Encoders of the same type can be dragged to the video wall to switch signals.

Video Wall Remove

If you want to delete a video wall, just select the video wall on the “Video Wall List”, then click “Remove”. A prompt window will pop up and you can delete it after clicking “Yes”.

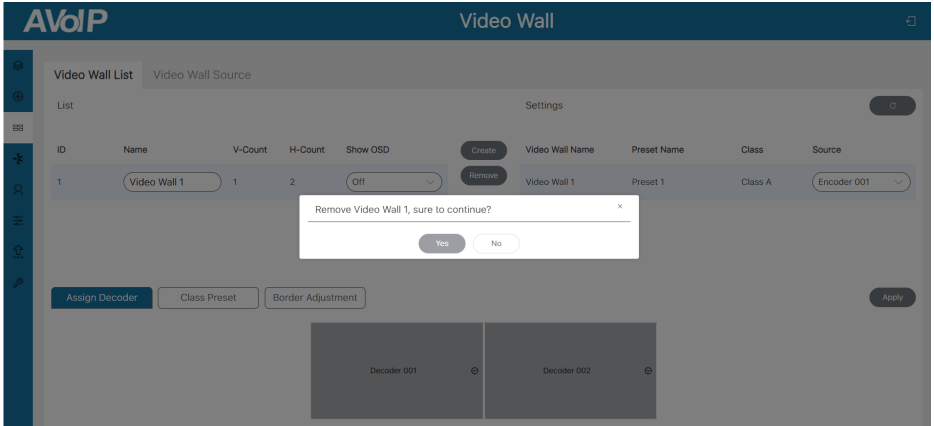

Notes:

- (1) Each Decoder can be set into a part of a video wall array. Each system can contain multiple video walls with different sizes. Each video wall can be assigned to different screens and different layouts that range from 1x2 up to 9x9.
- (2) The controller creates and manages the video wall configurations and provides a simplified control interface and API commands to third party control system.

7.2.4 Dante

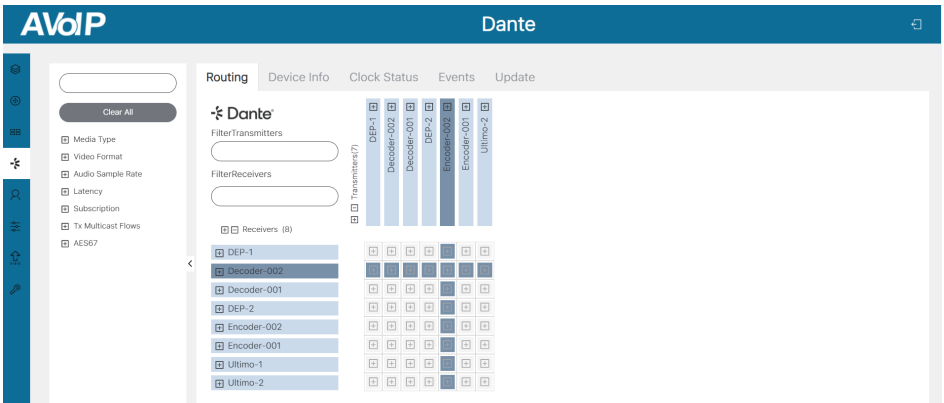

Routing

All devices in the system are displayed on this interface. Before setting the Dante routing, you can filter devices as required by checking the items on the left side of the interface, or directly enter the filter items in the input box of Filter Transmitters/Filter Receivers. If clicking “Clear All”, all filter items will be cleared.

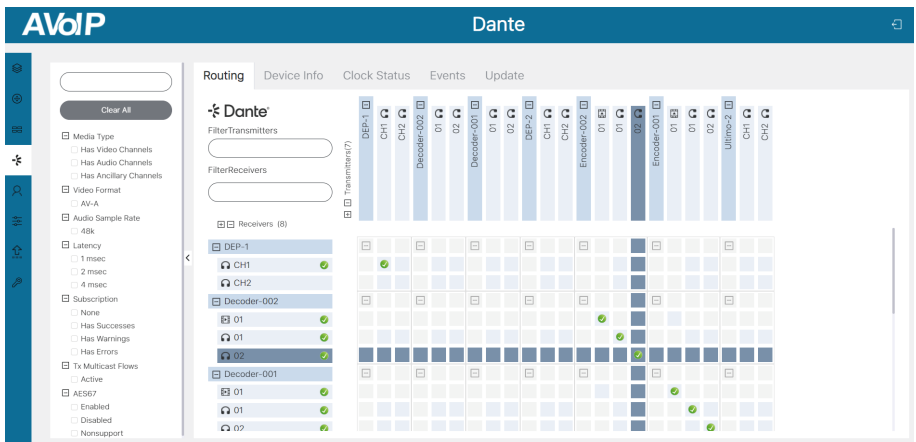

Click the “+” icons of Transmitters and Receivers to expand devices, then set the Dante routing according to your need.

The Dante routing of video or audio L/R channel can be set independently. After pairing the Dante AV-A™ devices on the Routing interface, video routing will refresh synchronously on the Matrix interface. At the same time, USB, IR, RS-232, CEC and audio routing will also follow the configuration and synchronize the refresh. Similarly, the video routing of Dante AV-A™ devices will be refreshed synchronously on the Routing interface after pairing videos on the Matrix interface.

Device Info

Routing		Device Info	Clock Status	Events	Update					
ID	Name	Model Name	Product Version	Dante Version	Primary Address	Primary Link Speed	Secondary Address	Secondary Link Speed		
1	DEP-1	DA22XLR-WP-US-V2	1.0.1	1.3.3.5	169.254.77.210	100Mbps	N/A	N/A		
2	Decoder-002	DAV-R	2.0.0	1.1.1.1	169.254.20.3	1Gbps	N/A	N/A		
3	Decoder-001	DAV-R	2.0.0	1.1.1.1	169.254.20.2	1Gbps	N/A	N/A		
4	DEP-2	DU-TR-22	1.0.1	1.2.1.1	169.254.5.252	100Mbps	N/A	N/A		
5	Encoder-002	DAV-T	2.0.0	1.1.1.1	169.254.10.5	1Gbps	N/A	N/A		
6	Encoder-001	DAV-T	2.0.0	1.1.1.1	169.254.10.1	1Gbps	N/A	N/A		
7	Ultimo-1	DP-R-22	1.0.0	4.2.8.2	169.254.213.123	100Mbps	N/A	N/A		
8	Ultimo-2	DU-TR-22	1.0.0	4.2.6.5	169.254.224.123	100Mbps	N/A	N/A		

The Device Info interface displays the information of devices in the system, including ID, name, model name, product version, Dante version, primary address, primary link speed, secondary address and secondary link speed. In addition, you can view details or configure each device after clicking the drop-down icon on the left side of ID.

Device Configuration

① **Receive:** The Receiver Channels displays the current receiver channels and the channels they are routed to. You can filter the channels by entering the items in the input box of Available Channels.

② **Transmit:** The Transmit Channels displays the selected transmit channels, and you can rename each channel. The Multicast Transmit Flows displays the current multicast flow, and you can add new multicast flows by clicking the “+” icon or delete the multicast flow by clicking “Delete”.

③ **Status:** You can view the manufacturer information (model name/manufacturer/product version), Dante information (Dante model/Dante software version) and interfaces (IP address/Mac Address).

④ **Device Config:** You can view/set the sample rate (44.1k/48k/88.2k/98k), encoding formats (PCM 16/24/32), and the device latency (2/3/4/5/10 msec), reboot the device, or clear the configuration of the device. Rename device is only available for third-party Dante devices. The characters “ ”, “_” and “.” are not allowed.

The screenshot shows the 'Device Info' tab for a Dante device. The 'Device Config' section includes:

- Rename Device:** A text input field containing 'Decoder-002' and an 'Apply' button.
- Encoding:** A dropdown menu set to 'PCM 24'. Below it, a message states: 'This device does not support encoding configuration.'
- Reset Device:** Two buttons: 'Reboot' and 'Clear Config'.
- Sample Rate:** A dropdown menu set to '48k' and a 'Sample Rate Pull-up' dropdown set to 'Select'. A message below reads: 'This device does not support sample rate pull-up configuration.'
- Device Latency:** A dropdown menu set to '4 msec'. A warning message states: 'Warning: This device is using a custom latency. Selecting another option will clear the custom value.'

⑤ **Network Config:** You can view/set the network configuration of the device.

The screenshot shows the 'Device Info' tab for a Dante device. The 'Network Config' section includes:

- Address:** Two radio buttons: 'Obtain an IP Address Automatically (default)' (selected) and 'Manually configure an IP Address'.
- IP:** Text input field with '169.254.20.2'.
- Netmask:** Text input field with '255.255.0.0'.
- DNS Server:** Text input field with '127.0.0.1'.
- Gateway:** Text input field with '169.254.1.1'. Below it, a message states: 'This feature cannot be configured.'
- Buttons:** 'Apply' and 'Revert' buttons.

⑥ **AES67 Config:** You can view/set the AES67 configuration of the third-party Dante device.
 Note: Dante AV-A™ devices does not support this setting.

The screenshot shows the 'Device Info' tab for a Dante device. The 'AES67 Config' section includes:

- AES67 Mode:** Two dropdown menus, both set to 'Disabled'.
- RTP Multicast Address Prefix:** A 'Current Prefix' set to 'No Set' and an 'New Address Prefix' text input field with '69' and an 'Apply' button.

Below the configuration section is a table listing device configurations:

>	2	Decoder-002	DAV-R	2.0.0	1.1.1	169.254.20.3	1Gbps
>	3	Decoder-001	DAV-R	2.0.0	1.1.1	169.254.20.2	1Gbps
>	4	DEP-2	DU-TR-22	1.0.1	1.2.1.1	169.254.5.252	100Mbps
>	5	Encoder-002	DAV-T	2.0.0	1.1.1	169.254.10.5	1Gbps
>	6	Encoder-001	DAV-T	2.0.0	1.1.1	169.254.10.1	1Gbps
>	7	Ultimo-1	DP-R-22	1.0.0	4.2.8.2	169.254.213.123	100Mbps

Clock Status

The Clock Status interface displays the clock status of devices in the system, including ID, name, Sync status, mute status, clock source, primary v1 multicast, primary v2 multicast, secondary v1 multicast, secondary v2 multicast and preferred leader.

Note: When the clock of the device synchronize the time of the leader Dante device, the Sync light is green, otherwise, both the Sync and mute lights are red and there is no signal output.

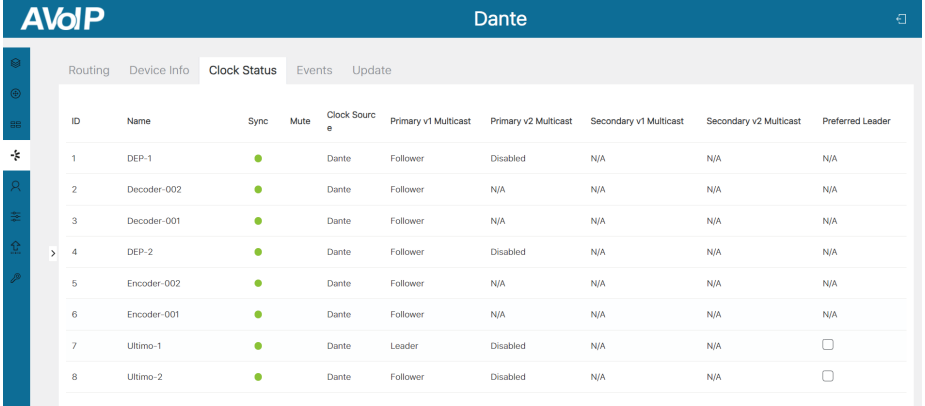

ID	Name	Sync	Mute	Clock Source	Primary v1 Multicast	Primary v2 Multicast	Secondary v1 Multicast	Secondary v2 Multicast	Preferred Leader
1	DEP-1	●		Dante	Follower	Disabled	N/A	N/A	N/A
2	Decoder-002	●		Dante	Follower	N/A	N/A	N/A	N/A
3	Decoder-001	●		Dante	Follower	N/A	N/A	N/A	N/A
4	DEP-2	●		Dante	Follower	Disabled	N/A	N/A	N/A
5	Encoder-002	●		Dante	Follower	N/A	N/A	N/A	N/A
6	Encoder-001	●		Dante	Follower	N/A	N/A	N/A	N/A
7	Ultimo-1	●		Dante	Leader	Disabled	N/A	N/A	<input type="checkbox"/>
8	Ultimo-2	●		Dante	Follower	Disabled	N/A	N/A	<input type="checkbox"/>

Events

The Events interface displays the event information of devices in the system, including number, timestamp, device name and event content.

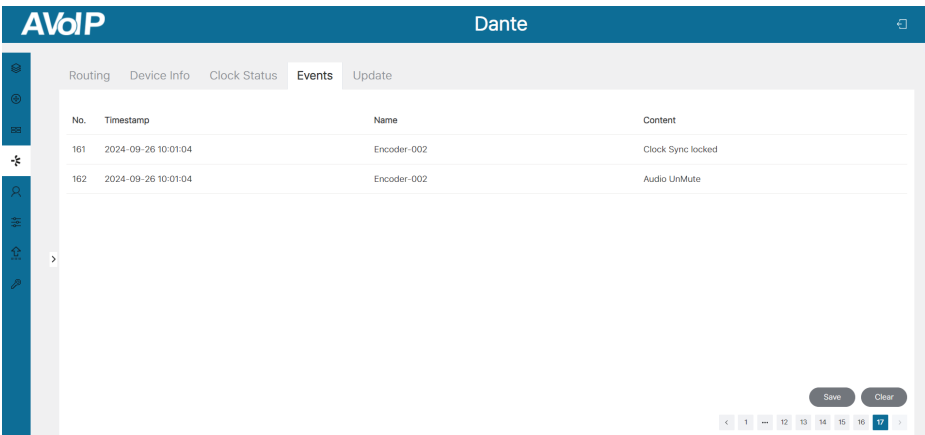

No.	Timestamp	Name	Content
161	2024-09-26 10:01:04	Encoder-002	Clock Sync locked
162	2024-09-26 10:01:04	Encoder-002	Audio UnMute

Save Clear

< 1 2 3 4 5 6 7 >

Update

Third-party Dante devices in the system can be updated on this interface. Click the drop-down menu to select the Dante device type “Ultimo/DEP”, then check the box to select the devices to be updated, and click “Upload Dante Firmware” to upload the update firmware. After loading, you need to click “Update All” to update firmware for all devices, or click “Update” to update firmware for a single device.

The screenshot shows the AVoIP Dante Update interface. At the top, there is a header with 'AVoIP' and 'Dante'. Below the header, there are tabs for 'Routing', 'Device Info', 'Clock Status', 'Events', and 'Update'. The 'Update' tab is active. On the left, there is a sidebar with navigation icons. The main content area has a dropdown menu set to 'Ultimo' and a button 'Upload Dante Firmware'. Below this is a table with columns: 'ID', 'Name', 'Firmware', 'Model', and 'Update All'. The table contains two rows of data:

ID	Name	Firmware	Model	Update All
1	Ultimo-1	4.2.8.2	UltimoX2	Update
2	Ultimo-2	4.2.6.5	UltimoX2	Update

7.2.5 User

The screenshot shows the AVoIP User management interface. At the top, there is a header with 'AVoIP' and 'User'. Below the header, there are buttons for 'Create' and 'Refresh'. The main content area has a table with columns: 'Name', 'Encoder IDs', and 'Decoder IDs'. The table contains one row of data:

Name	Encoder IDs	Decoder IDs	Remove
guest	all	all	Remove

Below the table, there is an 'Access' section with buttons for 'Apply', 'Select All', and 'Clear'. At the bottom, there are checkboxes for 'Encoder 001' and 'Encoder 002', and 'Decoder 001' and 'Decoder 002'.

On this page, you can add new user accounts with their own control privileges. This will allow you to create a unique login and limit features such as inputs and outputs that each person has access to. Follow steps below to create a new User.

Step 1: Click “Create”, a pop-up window will be shown as below.

The screenshot shows the 'Create User' pop-up window. It has a title bar with 'Create User' and a close button. The form contains three input fields: 'User Name', 'User Password', and 'Confirm Password'. Below the input fields is a 'Go' button.

Step 2: Input the User Name, User Password and Confirm Password. Then click “Go” to create the User.

Notes:

- (1) The user name requires a minimum of 6 characters and a maximum length of 12 characters. Special characters are not supported; The password has a minimum of 6 characters and a maximum of 8 characters.
- (2) The Password and Confirm Password must be the same.

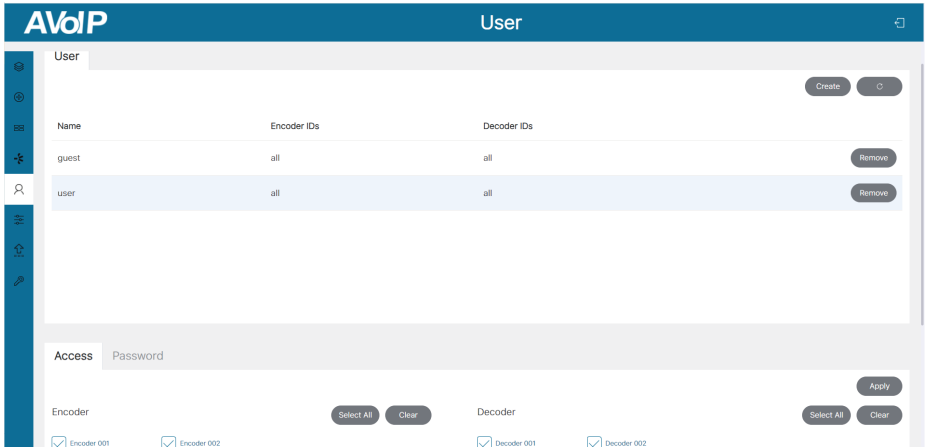

After the new User is created, you can select the Encoders and Decoders as required by checking the devices on the bottom of the User page one by one, or directly click “Select All” to select all devices in the system. Then click “Apply” to take effect.

Besides, you can click “Password” to change the User’s password, or click “Remove” to delete the User. If you want to login with the new User, just click the logout icon at the upper right corner of this page to log out, and then login with the new user name and password.

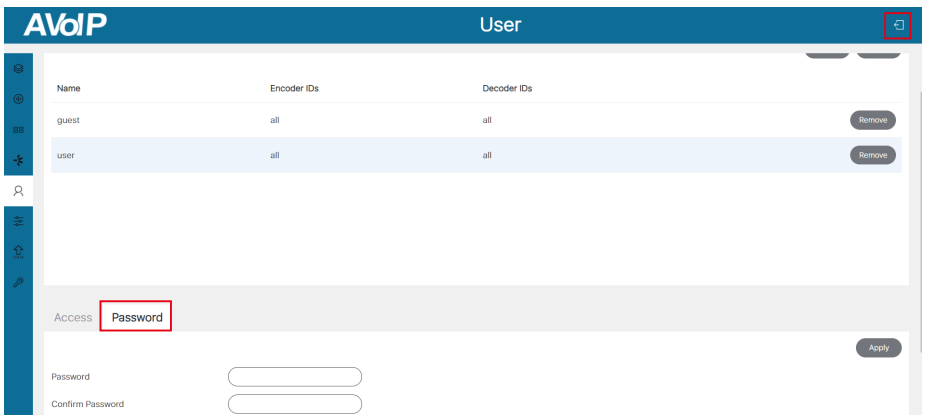

7.2.6 Controller Settings

The screenshot shows the AVoIP Controller Settings interface. At the top, there are three buttons: "Save", "Load", and "Clear". Below this, the "Controller Settings" section is expanded, showing "General" settings. The "General" section includes fields for Version (1.00.10), RS-232 BaudRate (57600), HTTPS (Off), Telnet (On), and Telnet Port (23). On the right side, there are fields for GUI Version (11.3), SSH (Off), SSH Port (22), and Domain Name (controller). Below the "General" section, there is a "Control Network" section with an "Apply" button and fields for DHCP (On), IP Address (192.168.6.100), Subnet Mask (255.255.255.0), and Gateway (192.168.6.1).

System Configurations: Click “Save” to save the current configuration; click “Load” to load the system configuration JSON file and replace the current system configurations (It’s strongly recommended to save the current configurations before loading); click “Clear” to clear system configurations already created and configured in the controller, and you need to set up the system again.

Controller Settings

① **General:** The general settings of the Controller. You can check the Controller Version, GUI Version and Domain Name. In addition, you can set the RS-232 BaudRate, HTTPS, Telnet, Telnet Port, SSH and SSH Port.

This screenshot shows the AVoIP Controller Settings interface, similar to the previous one but with the "Video Network" section expanded. The "General" and "Control Network" sections are visible at the top. The "Video Network" section has an "Apply" button and fields for DHCP (Off), IP Address (169.254.8.100), Subnet Mask (255.255.0.0), and Gateway (169.254.8.1). At the bottom, there is a "Controller Reset" section with three buttons: "Settings Reset", "Network Reset", and "Reset All".

② **Control Network:** The network port configuration of the Controller connected to the router, PC directly or network Switch in where the PC for control is. When DHCP is set to “Off”, you can manually set the IP Address, Subnet Mask and Gateway as required, then click “Apply” to take effect. When DHCP is set to “On”, the system will search and fill the IP Address with the one assigned by the router automatically.

Note: When DHCP is set to “Off” which is in Static IP mode, the network settings of Control LAN and PC should stay in same network segment. Otherwise, the controller Web GUI can not be accessed from PC until you change PC network settings in same network segment.

③ **Video Network:** The network port configuration of the Controller connected to the network where the Encoders and Decoders stay. When DHCP is set to “Off”, you can manually set the IP Address, Subnet Mask and Gateway as required, then click “Apply” to take effect. When DHCP is set to “On”, the system will search and fill the IP Address with the one assigned by the router automatically.

Note: When DHCP is set to “Off” which is in Static IP mode, the network settings of Video LAN and Encoders/Decoders should stay in same network segment. Otherwise, Encoders/Decoders would be showed as offline. In this case, you should change Video LAN or Encoders/Decoders IP settings to be in same network segment to bring Encoders/Decoders back online. If the Encoders/Decoders are actually alive in the system but with incorrect network segment settings, even though Encoders/Decoders are showing offline, their network settings including IP address can be changed and set.

④ **Controller Reset:** Click “Settings Reset” to reset controller all settings except network settings; Click “Network Reset” to reset controller network settings; Click “Reset All” to reset controller all settings including network settings.

7.2.7 Firmware Update

Encoder					Decoder			
ID	IP/MAC	Firmware	MCU Firmware	SS Firmware	ID	IP/MAC	Firmware	MCU Firmware
1	169.254.10.1 6C:DF:FB:00:F3:35	3.01.17	1.03.29 1.00.02		1	169.254.20.2 6C:DF:FB:00:F3:52	3.01.17	1.02.26 1.00.02
2	169.254.10.5 6C:DF:FB:01:1F:E6	3.01.17	1.03.29 1.00.02		2	169.254.20.3 6C:DF:FB:01:1F:EC	3.01.17	1.02.26 1.00.02

① **Upload User EDID 1/2:** Click the button to open an EDID binary file and upload it to User EDID 1/2.

② **Upload Decoder Logo Picture:** Click the button to upload the Decoder Logo Picture. Then click “Update All” to apply the picture for all Decoders or click “Update” to apply the picture for a single Decoder.

Note: The jpg picture must be greater than 4kB, less than or equal to 512kB, and the resolution of the picture must be less than or equal to 1920x1080.

- ③ **Upload Controller Firmware:** Click the button to upload the Controller update firmware.
- ④ **Upload Encoder or Decoder Firmware:** Click the button to upload the Encoder/Decoder update firmware. After loading, you need to click “Update All” to update firmware for all Encoders/Decoders, or click “Update” to update firmware for a single Encoder/Decoder.

7.2.8 Password

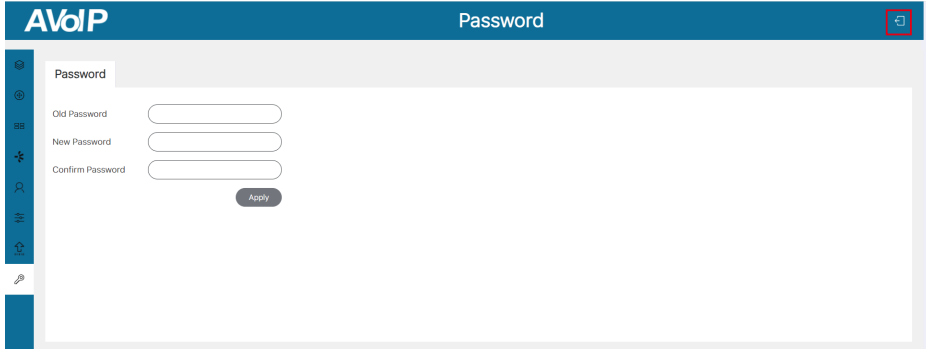

On this page, you can change the password by inputting the Old Password, New Password and Confirm Password, and then clicking “Apply” to take effect.

Notes:

- (1) *The password requires a minimum length of 6 characters and a maximum of 8 characters. Special characters are not supported.*
- (2) *The New Password can't be the same as Old Password.*
- (3) *The New Password and Confirm Password must be the same.*
- (4) *After changing password, the system will skip to the Web GUI login interface automatically. You need to log in the Web GUI again with the new password.*

In addition, there is a logout icon in the upper right corner of each page of the Web GUI. Clicking the icon will exit the Web GUI and automatically skip to the login interface.

8. Application Example

Ultimo Dante Audio Encoder

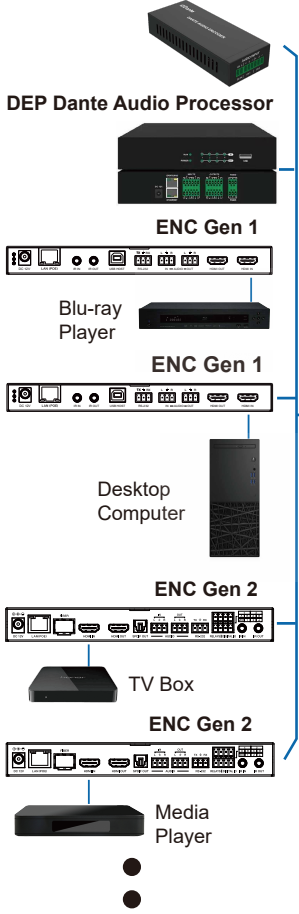

Ultimo Dante Audio Decoder

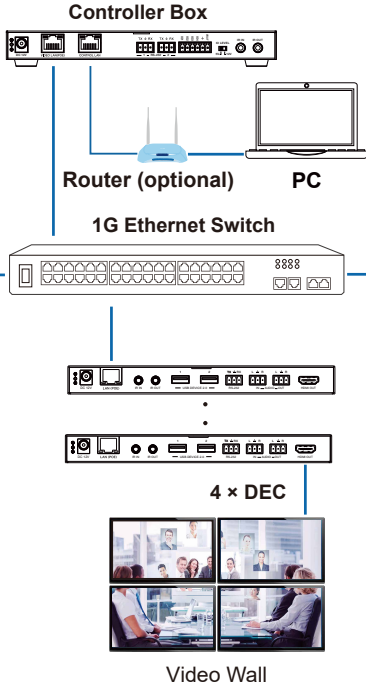
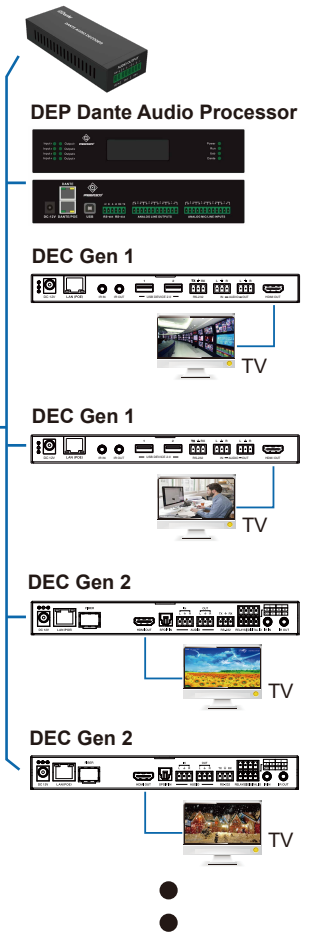

Notes:

(1) The Controller has two LAN ports, one is Video LAN and the other one is Control LAN. The purpose of designing Controller with two LAN ports is to isolate audio/video (AV) network from control network. So to make AV network as an independent network which can not be accessed from control network directly, it's for bringing network security and avoiding AV network traffic flowing into the network in which the controls and managements are for the IP system.

The strongly recommended system setup is connecting Video LAN and Encoders/Decoders in a network Switch, connecting Control LAN and PC in another network Switch. The controls from Control LAN can be achieved by Web GUI/Telnet or SSH login/API commands, all these controls can be bridged by the Controller and applied onto Video LAN. The two LANs are isolated.

For simple usage, you can only connect all Encoders/Decoders and Video LAN and PC RJ-45 port into a single network, and let the Control LAN port not-connected (floating), as Video LAN also supports Web GUI/Telnet or SSH login/API commands controls, this seems "convenient" for general use scenarios, but this is only suggested for system in which there is no network isolation requirement or network traffic non-sensitive.

Only Control LAN connected while Video LAN floating, this is not allowed.

(2) For the default IP mode of Control LAN port of the Controller Box is DHCP, the PC also needs to be set to "Obtain an IP address automatically" mode, and an optional DHCP server (e.g. network router) is recommended in the system.

(3) If there is no DHCP server in the system, 192.168.6.100 will be used as the IP address of Control LAN port. You need to set the IP address of the PC to be in the same network segment. For example, set PC's IP address as 192.168.6.88.

(4) You can access the Web GUI by inputting URL "http://controller.local" or the Control LAN port IP address 192.168.6.100 (in case of no optional router) on your computer's browser.

(5) No need to care about settings of Video LAN port of the Controller Box, as they are managed by Controller automatically (Default).

(6) When the Network Switch does not support POE, the Encoder, Decoder and Controller Box should be powered by DC power adapter.